



Drop Forged Rivetless Chains



DROP FORGED RIVETLESS CHAINS FOR FEED & WASHING TABLES

Cobalt Chains drop forged rivetless chains are typically used as overhead conveyors on automotive assembly lines, paint lines, appliance assembly lines, sugar mills and in the meat packaging industry.

These chains have no rotating parts, therefore suffer less from the abrasion caused by sand/dirt, that can come into the mill with the cane. All parts and heat-treated and "T" pins ensure positive locking action in the sidebars.

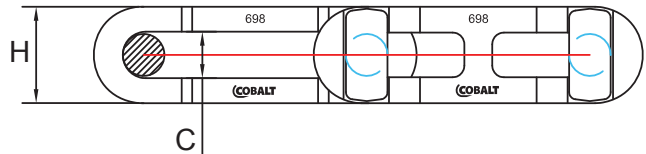
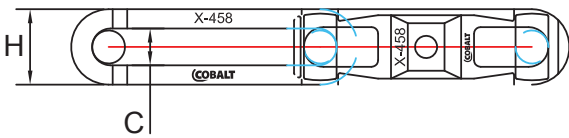
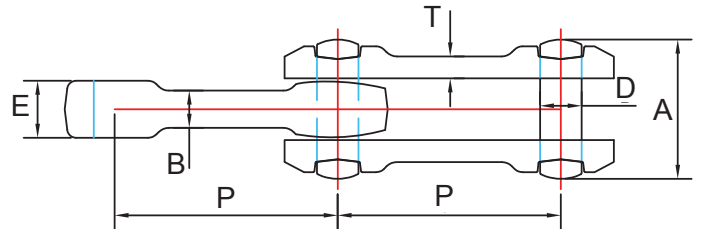
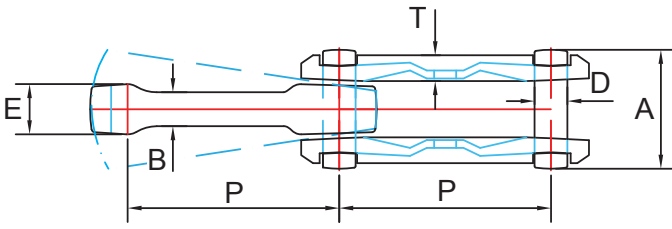

X Type

Standard Type

Drop Forged Rivetless Chains										
Chain	Pitch	E	Sidebar		Pin		B	C	Minimum Ultimate Strength	Weight
			T	H	D	A				
			in							
CX348	3.015	0.75	0.44	1.06	0.50	1.75	0.50	0.56	24,010	2.20
CX458	4.000	1.00	0.50	1.44	0.63	2.19	0.69	0.69	48,020	3.23
C468HT	4.031	1.63	0.44	1.88	0.75	3.31	1.19	0.88	70,030	8.06
CX678	6.031	1.31	0.75	2.00	0.88	3.00	0.81	1.00	85,050	6.71
C698HT	6.031	1.56	0.56	2.69	1.13	3.75	1.00	1.25	135,540	11.42
C998HT	9.031	1.56	0.31	2.50	1.13	3.88	1.00	1.13	135,540	9.00

Note: X Type is Double Flexing



**DROP FORGED RIVETLESS CHAINS FOR
FEED & WASHING TABLES**

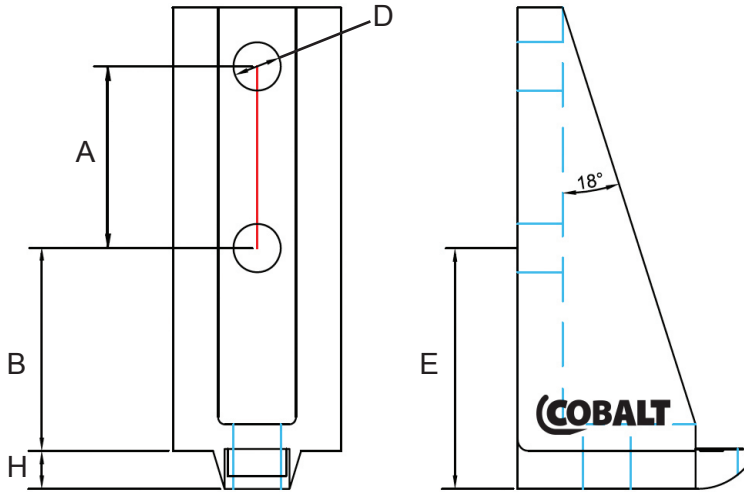

S22 Attachments						
Chain	D	A	B	H	E	Weight lbs
	in					
X458	0.56	2.00	1.93	0.31	2.25	1.60
468	0.53	2.00	2.23	0.42	2.86	1.80
X678	0.69	2.25	2.56	0.31	2.86	4.70
698	0.79	2.50	3.50	0.43	3.94	9.80
998	0.81	3.00	2.75	0.63	3.25	11.30

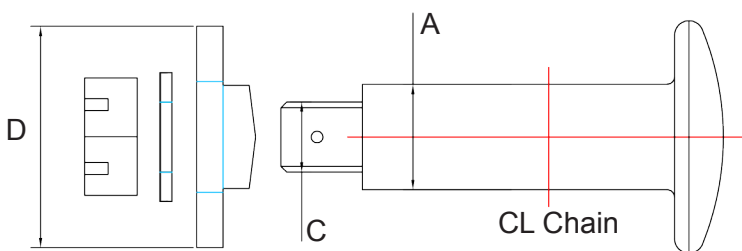

Master/Repair Pin			
Chain	A	C	Weight lbs
	in		
X348	0.500	0.400	0.20
X458	0.625	0.500	0.25
468	0.750	0.625	0.60
X678	0.875	0.625	1.00
698	1.125	0.750	1.80
998	1.125	0.750	1.80



Exceptional Performance, Superior Results

